

## N5069 Optical Node

### 4x4 Fully Segmentable

The N5069 1.2 GHz is a 4-output 4x4 fully segmentable optical node that is capable of providing up to 59.1 dBmV output at 1218 MHz with an optical input range from -8 dBm to +2 dBm. The node can have up to four optical receivers and four optical transmitters. The N5069 is RPhy capable and is compatible with the Harmonic pebble module. The N5069 optical node is compatible with the legacy SA6940 platform so it can be directly dropped into the existing SA6940 footprint to upgrade the HFC network to 1.2GHz bandwidth without re-splicing the cable. If the existing housing must be replaced the port configuration is the same as the legacy SA6940.

### Features

- ◆ Four driven output ports
- ◆ Compact size for a 4x4 segmentable node (8.44" H x 20.22" W x 10.73" D)
- ◆ -20.0 dB directional coupler test points
- ◆ Built-in bridger switching for managing the reverse path @ 0, -3.0, -6.0, and -26.0 dB (open) with active status monitoring (optional)
- ◆ Standard push on "F" connectors can be used on all test points
- ◆ DFB, CWDM, & DWDM transmitters available
- ◆ Remote PHY module is available for digital fiber link (option)
- ◆ Plug-in forward and reverse configuration modules allows for easy field reconfiguration to add or remove segmentation as needed
- ◆ 85% efficient 40/90 VAC switch-mode power supply with built-in Triac surge protection

# Block Diagrams

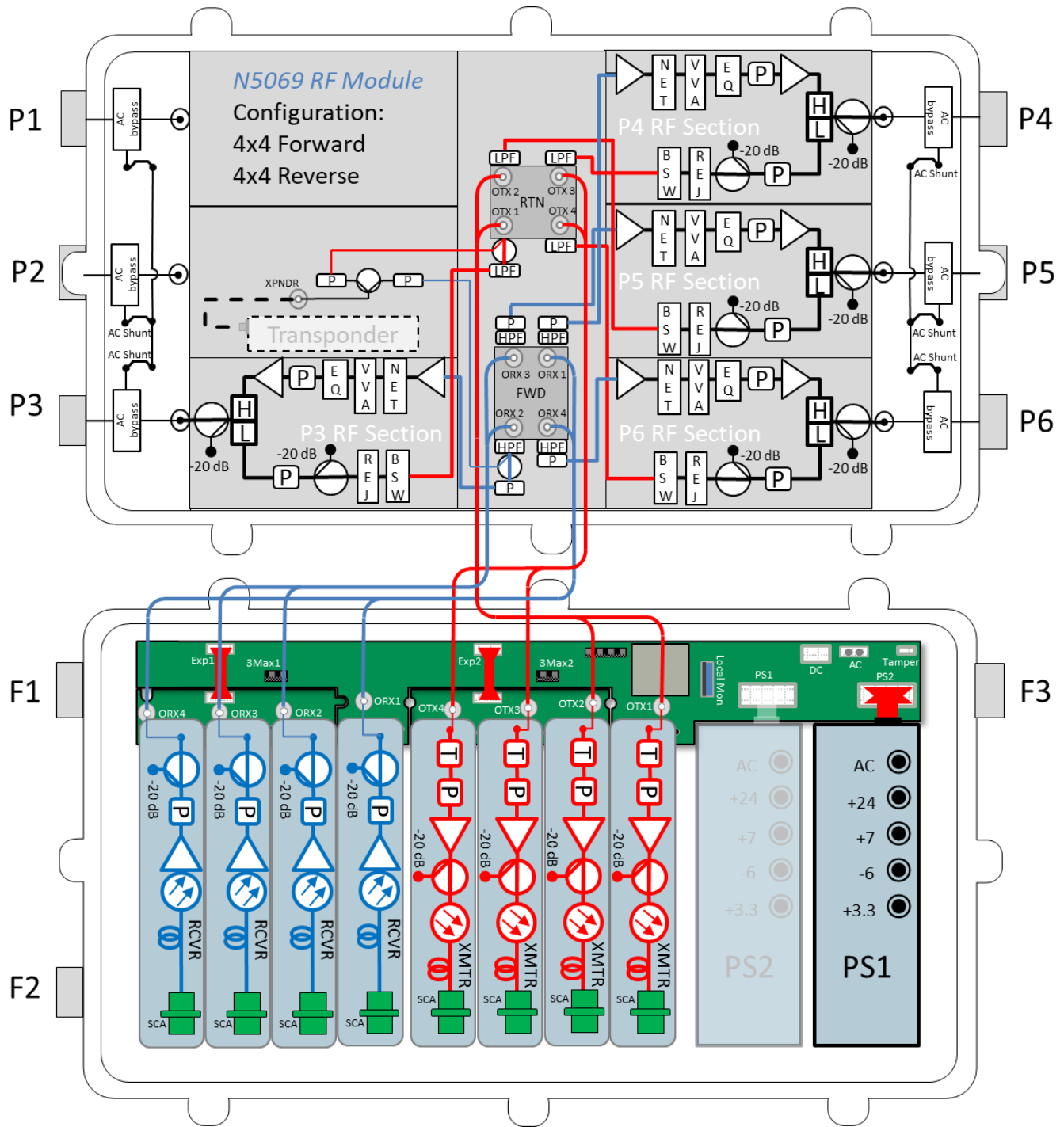

N5069 Block Diagram (4x4 Segmented Optical Node 1218 MHz)  
Analog Transmitters

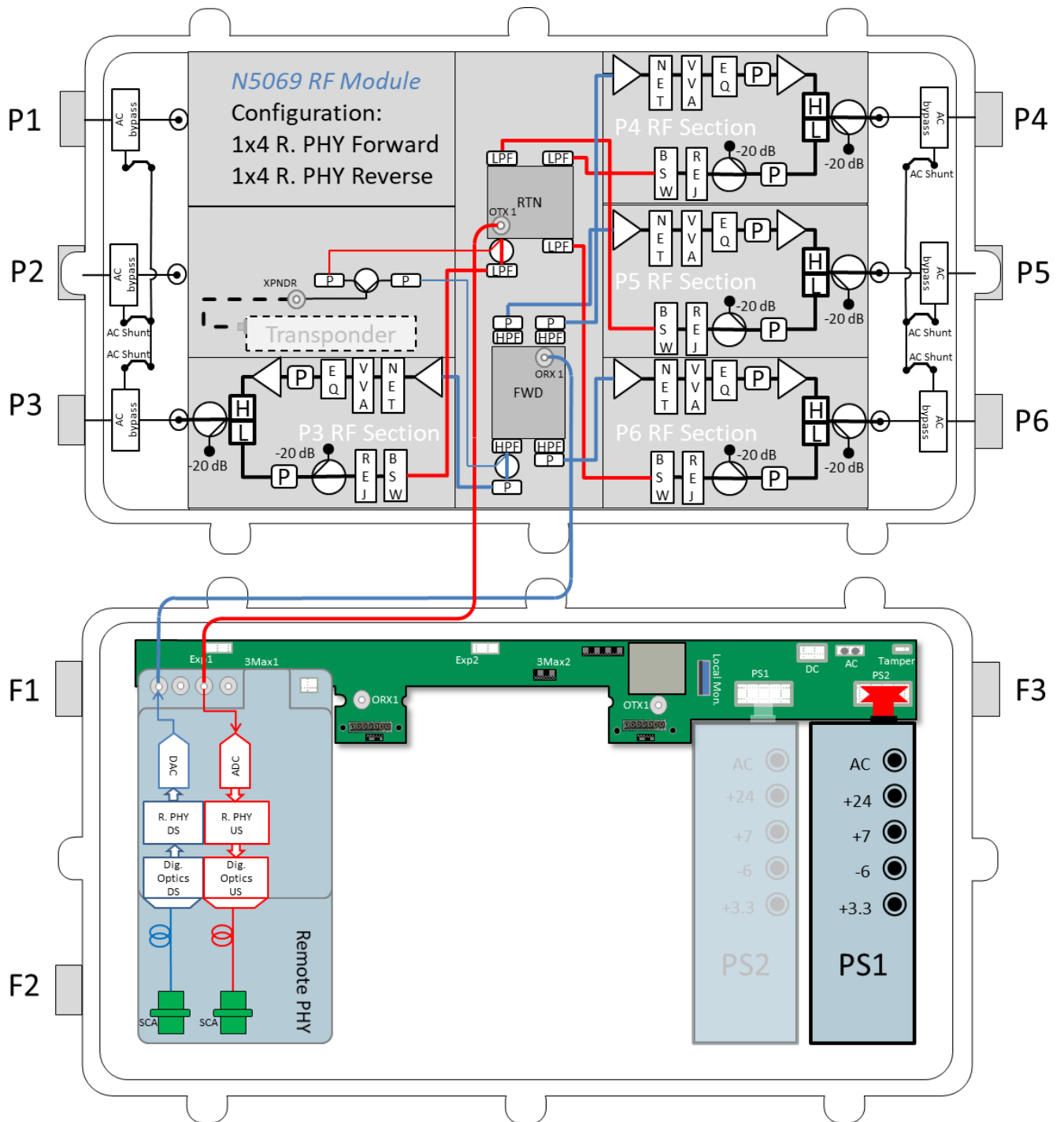

N5069 Block Diagram (1x4 Optical Node 1218 MHz)  
 Remote PHY Module

# Specifications 42/53

N5069 4-Output (Forward and Reverse Segmentable Optical Node 1218 MHz)						
Parameter	Conditions	Units	Min	Typ.	Max	Notes
Downstream Station (including FWD Configure Board unless otherwise noted), Port 3, Port 4, Port 5, Port 6						
Downstream Passband	42/53 Split	MHz	54	-	1218	
Input Current Capacity	15	A	-	-	15	
Hum Modulation	5 to 1218 MHz	dBc	65	-	-	Time Doman @ 15A
RF Input Level	Analog Level into FWD Configure Board Input	dBmV/ch	26	-	-	
Gain (Ref @ 1218MHz)	With 1x4 FWD Config Board (Config Bd IL: -10dB)	dB	32	33	34	±1dB stability over Node's Operating Temperature Range
	With 2x2 FWD Config Board (Config Bd IL: -10dB)	dB				
	With 4x4 FWD Config Board (Config Bd IL: -10dB)	dB				
Port to Port Isolation	54 to 1218 MHz	dB	-	-	-50	Note 3
Response Flatness	with FWD Configure Board	dB	-1	-	1	
Output Return Loss	54 to 1218MHz	dB	-	-	-16	Note 5
RF Test Point Level	-	dB	-20.5	-20	-19.5	Note 6
RF Output Level	54/105/550/750/870/1002/1218 MHz	dBmV	38/39/47/50.6/52.7/55.1/59			Analog Reference, Note 4
			32/33/41/44.6/46.7/49.1/53			Digital level, Note 4
Operational Slope	54/105/550/750/870/1002/1218 MHz	dB	0/1/9/12.6/14.7/17.1/21			
Slope Tolerance	-	dB	±1			
Slope Range	Min Slope = 10dB	dB	11	-	-	
CCN	21dB Slope	dB	54	56	-	Note 1a
CSO	30ch Analog (55.25-253.25MHz) + SCQAM (261-1215MHz) Digital is -6dB from Analog	dBc	-	-65	-61	
CTB		dBc	-	-70	-68	
XMOD	59dBmV Po @ Fc=1215MHz (analog ref level)	dBc	-	-	-64	
MER	All Digital, 21dB Slope, 160ch SCQAM (75-1215MHz)	dB	40	-	-	Note 1b
BER		-	-	-	10 <sup>-9</sup>	
Spurious	-	dBc	-	-	-70	
RF-Tray NF @ +21dB Slope	54/550/1002/1218MHz	dB	12			Without FWD Configure Board
Station NF @ +21dB Slope	54/550/1002/1218MHz	dB	19/19/18.5/18			Note 3
Upstream Station (including the RTN Configure Board unless otherwise noted), Port 3, Port 4, Port 5, Port 6						
Upstream Passband	42/53 Split	MHz	5	-	42	
Port to Port Isolation	5 to 42 MHz	dB	-	-	-50	Note 3
Response Flatness	5 to 42 MHz	dB	-0.75	-	0.75	
Insertion Loss	Without the RTN configure board, REF @ 25MHz With Rejection Filter jumper, LPF and -1dB RF atten	dB	-	-	-8.5	
Station Gain	RF Tray + All options of the RTN configure board REF @ 25MHz	dB	6	-	dB	±1dB stability over Node's Operating Temperature Range
Station Tilt	-	dB	-1	0	0.5	
Input Return Loss	5 to 42MHz	dB	-	-	-16	Note 5
RF Test Point Level	5 to 42 MHz	dB	-20.5	-20	-19.5	Note 6
Bridge SW Attenuation Range	BSW Default Setting Stages: 0dB, -3dB, -6dB and Open	dB	12	-	-	±0.5dB Atten Accuracy
RF Input Level	-	dBmV/ch	17	-	-	
Station Output to OTx	With all options of the RTN configure board	dBmV/ch	-	23	-	
RF-Tray NF	Meas @ 25MHz	dB	-	7.5	8.5	Without RTN Configure Board
Station NF	Option: 4x1/4x4/2x2	dB	23/22/19			Note 3
CSO	6ch Loading for 5-42MHz: 7, 13, 19, 25, 31, 37MHz	dBc	-	-	-75	Note 2
CTB		dBc	-	-	-80	
XMOD		dBc	-	-	-80	
MER		dB	40	-	-	
BER		-	-	-	10 <sup>-9</sup>	
Peak NPR	5-42MHz	dB	57	-	-	
Dynamic Range	@ NPR40dB	dB	30	-	-	

Parameter	Conditions	Units	Min	Typ.	Max	Notes
<b>Optical Section: Forward Receiver Module</b>						
Optical Wavelength	-	MHz	1260	-	1620	
Optical Input Range	Optical AGC	dBm	2	-	-4	
Optical Return Loss	SC/APC	dB	40	-	-	
Responsivity	1310 nm	mA/mW	0.8	-	-	
	1550 nm		0.95	-	-	
RF Bandwidth	-	MHz	54	-	1218	
Frequency Response	-	dB	-0.5	-	0.5	
Tilt	Reference from 54MHz	dB	0	-	1	
Optical Input DC Testpoint	1310 nm	V/mW	0.9	1	1.1	
	1550 nm		1	1.1	1.21	
RF Output Test Point Level	-	dB	-20.5	-20	-19.5	
RF Output Level at 2 to -4dBm	Analog Reference	dBmV/ch	26	-	-	@ 3.4% OMI/ch
Optical Input Level	Digital	dBmV/ch	20	-	-	
MER	All Digital 42/54 Split, 21±1dB Slope 160ch SCQAM (75-1215MHz)	dB	40	-	-	Note 1b, 7
BER		-	-	-	10 <sup>-9</sup>	
<b>Optical Section: Analog Return Transmitter Module</b>						
Optical Wavelength	$\lambda_c \pm 20\text{nm}$ , ITU-T, DFB	nm	1271	-	1611	
Optical Output Power	±1dB Stability Over the Node's Operating Temperature Range	mW	2	-	10	See Ordering Matrix for Opt Power Model
Optical Return Loss	SC/APC	dB	40	-	-	
Optical DC Testpoint	-	V/mW	0.9	-	1.1	
RF Bandwidth	-	MHz	5	-	210	
Frequency Response	-	dB	-0.75	-	0.75	
Tilt	Reference from 54MHz	dB	-0.5	-	1	
Laser Input Testpoint Level	-	dB	-20.5	-20	-19.5	
RF Input Level	Upstream RF Level from RF-Tray Into OTx	dBmV/ch	21	22	23	
CNR	6ch Loading, 5-42MHz: 7, 13, 19, 25, 31, 37MHz	dB	50	-	-	Note 8
CSO		dBc	-	-	-55	
CTB		dBc	-	-	-60	
XMOD		dBc	-	-	-60	
MER	6ch Loading for 5-42MHz: 7, 13, 19, 25, 31, 37MHz	dB	40	-	-	Note 2, 8
BER		-	-	-	10 <sup>-9</sup>	
NPR	5 - 42MHz Noise Loading, Test with QRR/DRR300	dB	40/16	-	-	Note 8
<b>Optical Section: Digital Return Transmitter Module</b>						
Optical Wavelength	1310	nm	1290	1310	1330	
	ITU-T CWDM		1271	-	1611	
	ITU-T, DWDM, 100GHz Spacing		1577	-	1528.8	
Optical Output Power	1310	dBm	-5	-	1	
	CWDM		0	-	3	
	DWDM		2	-	7	
Optical Return Loss	SC/APC	dB	40	-	-	
RF Bandwidth	-	MHz	5	-	42	
Frequency Response	Test with QDR/DDR	dB	-0.75	-	0.75	
RF Input Testpoint Level	-	dB	-20.5	-20	-19.5	
RF Input Level	Upstream RF Level from RF-Tray Into OTx	dBmV/ch	16	22	28	
MER	6ch Loading for 5-42MHz: 7, 13, 19, 25, 31, 37MHz	dB	38	-	-	Note 2, 9
BER		-	-	-	10 <sup>-9</sup>	
NPR	5-42MHz Noise Loading, Test with QDR/DDR	dB	40/18	-	-	Note 9

**Notes:**

- (1a) Factory Digital Loading for testing: 256QAM (261 to 999MHz) + 1x192MHz OFDM, Source MER ≥ 43dB, MER/BER test frequencies: 261, 555, 747, 831, 999MHz
- (1b) Factory Digital Loading for testing: 256QAM (57 to 999MHz) + 1x192MHz OFDM, Source MER ≥ 43dB, MER/BER test frequencies: 57, 261, 555, 747, 831, 999MHz
- (2) 64QAM, Source MER ≥ 43dB
- (3) RF-Tray with Configure Board
- (4) ± 1dB accuracy
- (5) Production Return Loss test limit is -16.5dB
- (6) Production TP level test limit is -20 ± 0.5dB
- (7) Downstream Link: Optical Link + RF-Tray. Po @ Fc=1215MHz = 53±1dBmV (Digital Level), Test with STD FT3UD-1310 or EMTx, 20km of fiber, Rx optical power = 0dBm
- (8) Upstream Link: RF-Tray + Optical Link. -10dBm rec'd optical power, QRR/DRR300 RF atten 10dB (RF output = 30 to 35dBmV/ch)
- (9) Upstream Link: RF-Tray + Optical Link. QDR/DDR output = 30 to 42dBmV/ch. Fiber Length: 40km for 1310nm, 80km for CWDM, 100km for DWDM

# Specifications 85/105

N5069 4-Output (Forward and Reverse Segmentable Optical Node 1218 MHz)						
Parameter	Conditions	Units	Min	Typ.	Max	Notes
Downstream Station (including FWD Configure Board unless otherwise noted), Port 1, Port 3, Port 4, Port 6						
Downstream Passband	85/105 Split	MHz	105	-	1218	
Input Current Capacity	15	A	-	-	15	
Hum Modulation	5 to 1218 MHz	dBc	65	-	-	Time Doman @ 15A
RF Input Level	Analog Level into FWD Configure Board Input	dBmV/ch	26	-	-	
Gain (Ref @ 1218MHz)	With 1x4 FWD Config Board (Config Bd IL: -10dB)	dB	32	33	34	±1dB stability over Node's Operating Temperature Range
	With 2x2 FWD Config Board (Config Bd IL: -10dB)	dB				
	With 4x4 FWD Config Board (Config Bd IL: -10dB)	dB				
Port to Port Isolation	105 to 1218 MHz	dB	-	-	-50	Note 3
Response Flatness	With FWD Configure Board	dB	-1	-	1	
Output Return Loss	105 to 1218MHz	dB	-	-	-16	Note 5
RF Test Point Level	-	dB	-20.5	-20	-19.5	Note 6
RF Output Level	105/550/750/870/1002/1218 MHz	dBmV	39/47/50.6/52.7/55.1/59			Analog Reference, Note 4
			33/41/44.6/46.7/49.1/53			Digital level, Note 4
Operational Slope	105/550/750/870/1002/1218 MHz	dB	0/8/11.6/13.7/16.1/20			
Slope Tolerance	-	dB	±1			
Slope Range	Min Slope = 10dB	dB	11	-	-	
CCN	20dB Slope	dB	54	56	-	Note 1a
CSO	25ch Analog (109.25-253.25MHz) + SCQAM (261-1215MHz)	dBc	-	-65	-61	
CTB	Digital is -6dB from Analog	dBc	-	-70	-68	
XMOD	59dBmV Po @ 1218MHz (analog ref level)	dBc	-	-	-64	
MER	All Digital, 20dB Slope	dB	40	-	-	Note 1b
BER	160ch SCQAM (105 to 1215MHz)	-	-	-	10 <sup>-9</sup>	
Spurious	-	dBc	-	-	-70	
RF-Tray NF @ +20dB Slope	@ 85/550/1002/1218MHz	dB	12			Without FWD Configure Board
Station NF @ +20dB Slope	@ 85/550/1002/1218MHz	dB	19/19/18.5/18			Note 3
Upstream Station (including the RTN Configure Board unless otherwise noted), Port 3, Port 4, Port 5, Port 6						
Upstream Passband	85/105 Split	MHz	5	-	85	
Port to Port Isolation	5 to 85 MHz	dB	-	-	-50	Note 3
Response Flatness	5 to 85 MHz	dB	-0.75	-	0.75	
Insertion Loss	Without the RTN configure board, REF @ 25MHz With Rejection Filter jumper, LPF and -1dB RF atten	dB	-	-	-8.5	
Station Gain	RF Tray + All options of the RTN configure board REF @ 25MHz	dB	6	-	dB	±1dB stability over Node's Operating Temperature Range
Station Tilt	-	dB	-1	0	0.5	
Input Return Loss	5 to 85 MHz	dB	-	-	-16	Note 5
RF Test Point Level	5 to 85 MHz	dB	-20.5	-20	-19.5	Note 6
Bridge SW Attenuation Range	BSW Default Setting Stages: 0dB, -3dB, -6dB and Open	dB	12	-	-	±0.5dB Atten Accuracy
RF Input Level	-	dBmV/ch	17	-	-	
Station Output to OTx	With all options of the RTN configure board	dBmV/ch	-	23	-	
RF-Tray NF	Meas @ 25MHz	dB	-	7.5	8.5	Without RTN Configure Board
Station NF	Option: 4x1/4x4/2x2	dB	23/22/19			Note 3
CSO	8ch Loading for 5-85MHz: 7, 19, 31, 43, 55.25, 67.25, 77.25, 83.25 MHz	dBc	-	-	-75	
CTB		dBc	-	-	-80	
XMOD		dBc	-	-	-80	
MER	8ch Loading for 5-85MHz: 7, 19, 31, 43, 51, 63, 79, 85 MHz	dB	40	-	-	Note 2
BER		-	-	-	10 <sup>-9</sup>	
Peak NPR	5-85MHz	dB	57	-	-	
Dynamic Range	@ NPR40dB	dB	30	-	-	



Parameter	Conditions	Units	Min	Typ.	Max	Notes
Optical Section: Forward Receiver Module						
Optical Wavelength	-	MHz	1260	-	1620	
Optical Input Range	Optical AGC	dBm	2	-	-4	
Optical Return Loss	SC/APC	dB	40	-	-	
Responsivity	1310 nm	mA/mW	0.8	-	-	
	1550 nm		0.95	-	-	
RF Bandwidth	-	MHz	54	-	1218	
Frequency Response	-	dB	-0.5	-	0.5	
Tilt	Reference from 105MHz	dB	0	-	1	
Optical Input DC Testpoint	1310 nm	V/mW	0.9	1	1.1	
	1550 nm		1	1.1	1.21	
RF Output Test Point Level	-	dB	-20.5	-20	-19.5	
RF Output Level at 2 to -4dBm	Analog Reference	dBmV/ch	26	-	-	@ 3.4% OMI/ch
Optical Input Level	Digital	dBmV/ch	20	-	-	
MER	All Digital 85/105 Split, 20 ±1dB Slope	dB	40	-	-	Note 1b, 7
BER	160ch SCQAM (105 to 1215MHz)	-	-	-	10 <sup>-9</sup>	
Optical Section: Analog Return Transmitter Module						
Optical Wavelength	$\lambda_c \pm 20\text{nm}$ , ITU-T, DFB	nm	1271	-	1611	
Optical Output Power	±1dB Stability Over the Node's Operating Temperature Range	mW	2	-	10	See Ordering Matrix for Opt Power Model
Optical Return Loss	SC/APC	dB	40	-	-	
Optical DC Testpoint	-	V/mW	0.9	-	1.1	
RF Bandwidth	-	MHz	5	-	210	
Frequency Response	-	dB	-0.75	-	0.75	
Tilt	Reference from 105MHz	dB	-0.5	-	1	
Laser Input Testpoint Level	-	dB	-20.5	-20	-19.5	
RF Input Level	Upstream RF Level from RF-Tray Into OTx	dBmV/ch	21	22	23	
CNR	8ch Loading, 5-85MHz: 7, 19, 31, 43, 55.25, 67.25, 77.25, 83.25MHz	dB	50	-	-	Note 8
CSO		dBc	-	-	-55	
CTB		dBc	-	-	-60	
XMOD		dBc	-	-	-60	
MER	8ch Loading for 5-85MHz: 7, 19, 31, 43, 51, 63, 79, 85MHz	dB	40	-	-	Note 2, 8
BER	-	-	-	-	10 <sup>-9</sup>	
NPR	5 - 85MHz Noise Loading, Test with QRR/DRR300	dB	40/11	-	-	Note 8
Optical Section: Digital Return Transmitter Module						
Optical Wavelength	1310	nm	1290	1310	1330	
	ITU-T CWDM		1271	-	1611	
	ITU-T, DWDM, 100GHz Spacing		1577	-	1528.8	
Optical Output Power	1310	dBm	-5	-	1	
	CWDM		0	-	3	
	DWDM		2	-	7	
Optical Return Loss	SC/APC	dB	40	-	-	
RF Bandwidth	-	MHz	5	-	85	
Frequency Response	Test with QDR/DDR	dB	-0.75	-	0.75	
RF Input Testpoint Level	-	dB	-20.5	-20	-19.5	
RF Input Level	Upstream RF Level from RF-Tray Into OTx	dBmV/ch	16	22	28	
MER	8ch Loading for 5-85MHz: 7, 19, 31, 43, 51, 63, 79, 85MHz	dB	38	-	-	Note 2, 9
BER	-	-	-	-	10 <sup>-9</sup>	
NPR	5 - 85MHz Noise Loading, Test with QDR/DDR	dB	40/18	-	-	Note 9

**Notes:**

- (1a) Factory Digital Loading for testing: 256QAM (261 to 999MHz) + 1x192MHz OFDM, Source MER ≥ 43dB, MER/BER Test Frequencies: 261, 555, 747, 831, 999MHz
- (1b) Factory Digital Loading for testing: 256QAM (105 to 999MHz) + 1x192MHz OFDM, Source MER ≥ 43dB, MER/BER Test Frequencies: 105, 261, 555, 747, 831, 999MHz
- (2) 64QAM, Source MER ≥ 43dB
- (3) RF-Tray with Configure Board
- (4) ±1dB accuracy
- (5) Production Return Loss test limit is -16.5dB
- (6) Production TP level test limit is -20 ± 0.5dB
- (7) Downstream Link: Optical Link + RF-Tray. Po @ 1218MHz = 53 ± 1dBmV (Digital Level), Test with STD FT3UD-1310 or EMTx. 20km of fiber, Rx optical power = 0dBm
- (8) Upstream Link: RF-Tray + Optical Link. -10dBm rec'd optical power, QRR/DRR300 RF atten 10dB (RF output = 30 to 35dBmV/ch)
- (9) Upstream Link: RF-Tray + Optical Link. QDR/DDR output = 30 to 42dBmV/ch. Fiber Length: 40km for 1310nm, 80km for CWDM, 100km for DWDM

## Receiver, Transmitter and Spare Parts

<b>RECEIVER AND TRANSMITTERS</b>	
XXX = Optical Connector Type (FC/UPC, FC/APC SC/APC & SC/UPC)	
<b>Part Number</b>	<b>Description</b>
090816-01XXX	Receiver, N50 MIMIC 1218 MHz
090817-01XXX	Transmitter N50 DFB Uncooled, Isolated 1310 nm 1.0 mW
090817-02XXX	Transmitter N50 DFB Uncooled, Isolated 1310 nm 2.0 mW
090817-03XXX	Transmitter N50 DFB Uncooled, Isolated 1310 nm 3.0 mW
090818-02XXX	Transmitter N50 DFB Uncooled, Isolated 1550 nm 2.0 mW
090818-04XXX	Transmitter N50 DFB Uncooled, Isolated 1550 nm 4.0 mW
090819-01XXX	Transmitter N50 DFB CWDM Uncooled, Isolated 1471 nm 2.0 mW
090819-02XXX	Transmitter N50 DFB CWDM Uncooled, Isolated 1491 nm 2.0 mW
090819-03XXX	Transmitter N50 DFB CWDM Uncooled, Isolated 1511 nm 2.0 mW
090819-04XXX	Transmitter N50 DFB CWDM Uncooled, Isolated 1531 nm 2.0 mW
090819-05XXX	Transmitter N50 DFB CWDM Uncooled, Isolated 1551 nm 2.0 mW
090819-06XXX	Transmitter N50 DFB CWDM Uncooled, Isolated 1571 nm 2.0 mW
090819-07XXX	Transmitter N50 DFB CWDM Uncooled, Isolated 1591 nm 2.0 mW
090819-08XXX	Transmitter N50 DFB CWDM Uncooled, Isolated 1611 nm 2.0 mW
090820-01XXX	Transmitter N50 DFB CWDM Uncooled, Isolated 1471 nm 3.0 mW
090820-02XXX	Transmitter N50 DFB CWDM Uncooled, Isolated 1491 nm 3.0 mW
090820-03XXX	Transmitter N50 DFB CWDM Uncooled, Isolated 1511 nm 3.0 mW
090820-04XXX	Transmitter N50 DFB CWDM Uncooled, Isolated 1531 nm 3.0 mW
090820-05XXX	Transmitter N50 DFB CWDM Uncooled, Isolated 1551 nm 3.0 mW
090820-06XXX	Transmitter N50 DFB CWDM Uncooled, Isolated 1571 nm 3.0 mW
090820-07XXX	Transmitter N50 DFB CWDM Uncooled, Isolated 1591 nm 3.0 mW
090820-08XXX	Transmitter N50 DFB CWDM Uncooled, Isolated 1611 nm 3.0 mW
090824-XXXXX	Transmitter N50, DWDM ITU CHXX XXXX.XX nm 10.0 mW
<b>FORWARD AND RETURN CONFIG MODULES</b>	
090850-01	Return Config Module 1x4 42MHz
090851-01	Return Config Module 2x2 42MHz
090852-01	Return Config Module 4x4 42MHz
090850-02	Return Config Module 1x4 85MHz
090851-02	Return Config Module 2x2 85MHz
090852-02	Return Config Module 4x4 85MHz
090850-03	Return Config Module 1x4 204MHz
090851-03	Return Config Module 2x2 204MHz
090852-03	Return Config Module 4x4 204MHz
090853-01	Forward Config Module 1x4 42MHz
090854-01	Forward Config Module 2x2 42MHz
090855-01	Forward Config Module 4x4 42MHz
090853-02	Forward Config Module 1x4 85MHz
090854-02	Forward Config Module 2x2 85MHz
090855-02	Forward Config Module 4x4 85MHz
090853-03	Forward Config Module 1x4 204MHz
090854-03	Forward Config Module 2x2 204MHz
090855-03	Forward Config Module 4x4 204MHz
<b>POWER SUPPLY</b>	
N50-90VPS	N50 40-90 VAC Power Supply
<b>REMOTE PHY Mounting Plate Kit</b>	
120631-01	KIT, N50 Remote PHY Plate Installation Kit
<b>AC ENTRY KITS</b>	
120634-01	AC Entry Right Installation Kit
120635-01	AC Entry Left Installation Kit



# Part Number Ordering Matrix

## N5069 4x4 Optical Node Configuration Sheet

Customer: \_\_\_\_\_

Created By: \_\_\_\_\_ Order Date: \_\_\_\_\_

### ORDERING MATRIX

October 20, 2022

Position	1	2	3	4	5	6	7	8	9	10	11	12	13	14	15	16	17	18	
PART NUMBER	5	S																	

3

#### BASE CONFIGURATION

A = FWD 1x4 REV 4x1 Nonsegmented  
1 Transmitter installed  
1 Receiver installed

C = FWD 2X2 REV 2X2 Forward & Return segmented  
2 Transmitters installed  
2 Receivers installed

G = FWD 4X4 REV 4X4 Forward & Return segmented  
4 Transmitters installed  
4 Receivers installed

L = FWD 1X4 REV 4X1 Nonsegmented (See Note 2)  
1 Remote PHY 1x1 module installed (1 DS + 1 US)

M = FWD 2X2 REV 2X2 Forward & Return Segmented (See Notes 1 & 2)  
2 Remote PHY 1x1 modules installed (2 DS + 2 US)

N = FWD 2X2 REV4X4 Forward & Return Segmented (See Notes 1 & 2)  
2 Remote PHY(1x2) modules installed (2 DS + 4 US)

P = FWD 1X4 REV 2X2 Forward Nonsegmented & Return Segmented (See Note 2)  
1 Remote PHY(1x2) module installed (1 DS + 2 US)

R = FWD 2X2 REV 2X2 Forward & Return segmented Digital RPD (See Note 2)  
with FWD analog RF overlay  
1 Remote PHY 1x2 module installed (1 DS + 2 US)  
1 Receiver installed

4

#### DIPLEX FREQUENCY SPLIT & OPTICAL CONNECTOR TYPE

Connector Split	SC/APC	SC/UPC	FC/APC	FC/UPC
4 = 42/53	A = 42/53	E = 42/53	J = 42/53	
5 = 55/70	B = 55/70	F = 55/70	K = 55/70	
6 = 65/85	C = 65/85	G = 65/85	L = 65/85	
8 = 85/105	D = 85/105	H = 85/105	M = 85/105	

#### TYPE DWDM: ITU Grid: C-Band, 100 GHz Spacing (10.0 mW)

19 = Channel 19 - 1562.23nm	35 = Channel 35 - 1549.32nm	51 = Channel 51 - 1536.61nm
20 = Channel 20 - 1561.42nm	36 = Channel 36 - 1548.52nm	52 = Channel 52 - 1535.82nm
21 = Channel 21 - 1560.61nm	37 = Channel 37 - 1547.72nm	53 = Channel 53 - 1535.04nm
22 = Channel 22 - 1559.79nm	38 = Channel 38 - 1546.92nm	54 = Channel 54 - 1534.25nm
23 = Channel 23 - 1558.98nm	39 = Channel 39 - 1546.12nm	55 = Channel 55 - 1533.47nm
24 = Channel 24 - 1558.17nm	40 = Channel 40 - 1545.32nm	56 = Channel 56 - 1532.68nm
25 = Channel 25 - 1557.36nm	41 = Channel 41 - 1544.53nm	57 = Channel 57 - 1531.90nm
26 = Channel 26 - 1556.56nm	42 = Channel 42 - 1543.73nm	58 = Channel 58 - 1531.12nm
27 = Channel 27 - 1555.75nm	43 = Channel 43 - 1542.94nm	59 = Channel 59 - 1530.33nm
28 = Channel 28 - 1554.94nm	44 = Channel 44 - 1542.14nm	60 = Channel 60 - 1529.55nm
29 = Channel 29 - 1554.13nm	45 = Channel 45 - 1541.35nm	61 = Channel 61 - 1528.77nm
30 = Channel 30 - 1553.33nm	46 = Channel 46 - 1540.56nm	62 = Channel 62 - 1527.99nm
31 = Channel 31 - 1552.52nm	47 = Channel 47 - 1539.77nm	63 = Channel 63 - 1527.22nm
32 = Channel 32 - 1551.72nm	48 = Channel 48 - 1538.98nm	64 = Channel 64 - 1526.44nm
33 = Channel 33 - 1550.92nm	49 = Channel 49 - 1538.19nm	
34 = Channel 34 - 1550.12nm	50 = Channel 50 - 1537.40nm	

#### TYPE REMOTE PHY MODULE CONFIGURATIONS (See Notes 1 & 2)

00= No Remote PHY Module  
MP= Mounting Plats Installed only  
11= 1 Down Stream + 1 Up Stream (1x1 module) Base options L, M or Q  
12= 1 Down Stream + 2 Up Stream (1x2 module) Base option N, P or R

#### Mux/DeMux Module for CWDM, DWDM or WDM

(For a 1X2 Mux or WDM use position 13)

MUX A -Use for 2X2, or ports 3 & 5 for 4X4

MUX B Ports 4 & 6 for 4X4 or 2X2, 2+2, With Optics Redundancy

0 = None  
A = FWD path 1291, 1293; REV path 1471, 1491 nm & common  
B = FWD path 1290, 1295; REV path 1591, 1611 nm & common  
C = FWD Path 1310, 1431; REV path 1451, 1551 nm & common  
P = DWDM 1291/CWDM 1471 nm  
W = WDM 1310/1550 nm

Future = \_\_\_λ1 \_\_\_λ2 \_\_\_λ3 \_\_\_λ4

#### SLOPE

MHz	550	750	870	1002	1218
E=	8.3	12.2	14.5	17.0	21.0
T=	6.3	10.2	12.5	15.0	19.0

#### HOUSING OPTIONS & POWER SUPPLY QUANTITY (See Note 1)

P = Complete Node - 1 Power Supply  
K = Upgrade kit - 1 Power Supply  
E = Complete Node - 2 Power Supplies  
F = Upgrade kit - 2 Power Supplies

#### STATUS MONITORING

0 = None  
D = DOCSIS HMS Transponder

#### CUSTOM

0 = None  
X = Determined by Product Management

5 & 6   
7 & 8   
9 & 10   
11 & 12

TRANSMITTER 1 - Primary 4X1, or Ports 3 & 4 for 2X2, Port 3 for 4X1  
TRANSMITTER 2 - Secondary 4X1 or Ports 5 & 6 for 2X2 or Port 5 for 4X1  
TRANSMITTER 3 - Secondary Ports 3 & 4 for 2X2 or Port 4 for 4X1  
TRANSMITTER 4 - Secondary Ports 5 & 6 for 2X2 or Port 6 for 4X1  
00 = NO TRANSMITTERS INSTALLED

REMOTE PHY MODULE ENTER "RP" FOR POSITIONS 5&6, 9&10

REMOTE PHY MODULE CONFIGURATIONS:

FILL IN POSITION 7&8 FOR RPD#1, 11&12 FOR RPD#2

#### ANALOG TRANSMITTER OPTIONS:

##### TYPE FP & DFB

00 = None  
D0 = Uncooled 1310 nm 1.0 mW FP  
H0 = Uncooled 1310 nm 2.0 mW FP W/SOLATOR  
J0 = Uncooled 1310 nm 1.0 mW DFB  
R0 = Uncooled 1310 nm 2.0 mW DFB  
B0 = Uncooled 1310 nm 3.0 mW DFB  
C0 = Uncooled 1550 nm 2.0 mW DFB  
Z0 = Uncooled 1550 nm 4.0 mW DFB

##### TYPE DFB CWDM 2.0 mW

A2 = Uncooled 1471 nm DFB CWDM (2.0 mW)  
G2 = Uncooled 1491 nm DFB CWDM (2.0 mW)  
V2 = Uncooled 1511 nm DFB CWDM (2.0 mW)  
L2 = Uncooled 1531 nm DFB CWDM (2.0 mW)  
W2 = Uncooled 1551 nm DFB CWDM (2.0 mW)  
M2 = Uncooled 1571 nm DFB CWDM (2.0 mW)  
N2 = Uncooled 1591 nm DFB CWDM (2.0 mW)  
T2 = Uncooled 1611 nm DFB CWDM (2.0 mW)

##### TYPE DFB CWDM 3.0 mW

A3 = Uncooled 1471 nm DFB CWDM (3.0 mW)  
G3 = Uncooled 1491 nm DFB CWDM (3.0 mW)  
W3 = Uncooled 1511 nm DFB CWDM (3.0 mW)  
N3 = Uncooled 1531 nm DFB CWDM (3.0 mW)  
T3 = Uncooled 1551 nm DFB CWDM (3.0 mW)

##### TYPE DFB CWDM 4.0, 5.0 & 6.0 mW

W4 = Uncooled 1551 nm DFB CWDM (4.0 mW)  
W5 = Uncooled 1551 nm DFB CWDM (5.0 mW)  
N5 = Uncooled 1591 nm DFB CWDM (5.0 mW)  
T5 = Uncooled 1611 nm DFB CWDM (5.0 mW)  
A6 = Uncooled 1471 nm DFB CWDM (6.0 mW)  
G6 = Uncooled 1491 nm DFB CWDM (6.0 mW)

13   
14

15

16

17

18

### NOTES:

- For Configurations with 2 Remote PHY modules 2 power supplies are required.
- For Configurations with remote PHY modules a 10GBASE SFP + single mode fiber optic transceiver submodule is needed for each RPD to establish the digital fiber link with the headend CCAP core.
- Example: 5NC4A2G20000A0EP00  
2X2 Forward & Reverse segmented node, 2 Receivers, TX1: CWDM 1471nm 2mW, TX2: CWDM 1491nm 2mW, 1 Mux/Demux module DWDM1291/1293/ CWDM1471/1491nm, 1.2GHz/Slope 21dB, complete node with single power supply.

## Power Consumption

Node Option	With Xponder	W/O Xponder
	Watts	Watts
4x4 Analog OTx & ORx	148	143
2x2 Analog OTx & ORx	127	122
1x4 Analog OTx & ORx	117	112
Dual RPD Node	154	154
Single RPD Node	128	128



ACI Communications, Inc.  
23307 66th Avenue South  
Kent, WA 98032

Rev H 10-20-2022 Printed in U.S.A.

ACI Communications, Inc. reserves the right to discontinue the manufacture or change specifications without prior notice on any parts illustrated in this data sheet. ACI and DSIM are registered trademarks and ASEM and ACION are trademarks of ACI. Other trademarks are the property of their respective owners, and ACI is in no way affiliated with these companies.