



## SDA 1.2G

### MiniFlex Super Distribution Amplifiers 1218 MHz

The ACI MiniFlex Super Distribution RF 1.2 GHz amplifiers are designed to work up to a high forward output of 57 dBmV. The return bandwidth split can be easily changed from 42 to 85 or 204 MHz with the use of field conversion kits. ACI's patented DSIM advanced technology keeps both the forward and return signals stable and reliable over extreme temperature swings. Having return band stabilization over temperature has become much more important as return band is increased to 204 MHz. Having the increased return gain of 28 dB enables these amplifiers to drop into existing designs from 750 MHz to 1 GHz.

#### Features

- ◆ 1218 MHz may be dropped into the 750, 870 or 1002 MHz spacing
- ◆ Easy upgrade to 85/105 or 204/258 MHz return bandwidth.
- ◆ Common housing platform
- ◆ -20.0 dB directional coupler test points
- ◆ 28 dB return gain
- ◆ RoHS Compliant
- ◆ Patented DSIM<sup>®</sup> Technology (smart, programmable AGC)
- ◆ Increased reliability with higher surge protection
- ◆ DSIM controlled return band AGC
- ◆ Pad adjustable forward and return EQ's
- ◆ DSIM Android & Apple iOS setup applications



## SDLE (Type 3A) 1218 MHz Amplifier Block Diagram

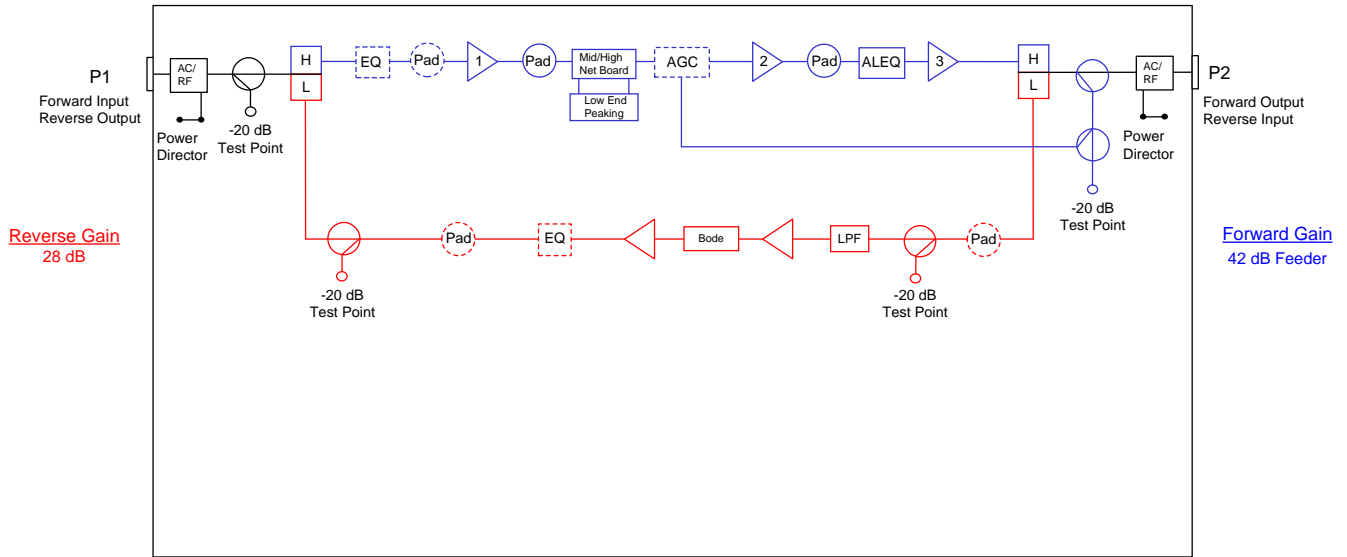

**Note:**

1. Forward gain stated at 1218 MHz with AGC. Reverse gain stated at 42, 85 or 204 MHz.

# Station Parameters 42/53

STATION PARAMETERS:		1218 MHz 42-53 MHz Split		SDA 1218 MHz		
		CONDITIONS	UNITS	SPECIFICATIONS		
Housing passband			MHz	5 to 1218		
Input current capacity	Any port, worst case		Amp	15		
Hum modulation	Time domain @ rated current above		-dBc	65 @ 5-42 MHz 65 @ 54-1218 MHz		
Return loss	Any port, worst case		dB	16.0		
<b>Test Points</b>						
Frequency range			MHz	5 to 42 (Reverse) / 54 to 1218 (Forward)		
Test point type	Directional coupler		N / A			
Test point level	Forward & reverse		-dB	20.0		
Test point accuracy	Forward & reverse		±dB	0.75		
<b>Station Slope</b>				SDAT	SDAM	SDLE
Operational slope - trunk & feeders	@ 54 / 550 / 1218 MHz		dB	0 / 8.1 / 19.0	0 / 8.1 / 19.0	0 / 8.1 / 19.0
Slope control type	Cable equalizers		dB	Pad Adjustable EQ's		
Slope control range	Includes cable equivalent		dB	-12.0 to +22		
Slope control steps	Equalizer value steps		dB	1.0		
<b>Station Group Delay</b>						
Group delay	Channel 2 (Std)			37		
Group delay	Channel 3	nSec / 3.58 MHz		16		
Group delay	Channel 4		10			
Group delay	Channel 5 & up		4			
<b>AGC</b>						
DSIM-A Single Pilot Channel AGC						
Pilot channel type	Up to 1002 MHz		N / A	Analog or QAM		
Compensation range			dB	System compensation input change +4/-8 @ 1218 MHz		
Accuracy			±dB	0.5		
Nominal loss	@ 77 °F (25 °C)		dB	6.25		
<b>Configuration</b>				SDAT	SDAM	SDLE
<b>Operational Specifications</b>						
Station flatness - Trunk	Normalized w/ 0 dB slope		±dB	0.35	-	-
Station flatness - Feeder	Normalized w/ 0 dB slope		±dB	0.50	0.50	0.30
Gain - Port 2 (W/DSIM)	+1.0 / -0 @ 1218 MHz		dB	38.0	48.0	42.0
Gain - Port 3 (W/DSIM)		dB	48.0	-	-	
Gain - Port 4 (W/DSIM)		dB	48.0	48.0	-	-
496 MHz analog channel loading, 79 channels + 660 MHz digital channel loading, 256 QAM at -6 dBc relative to its associated visual carrier						
<b>Station Referenced Output Levels</b>				SDAT	SDAM	SDLE
Port 2	@ 54 / 550 / 1218 MHz		dBmV	28.0 / 36.1 / 47.0	38.0 / 46.1 / 57.0	38.0 / 46.1 / 57.0
Port 3				38.0 / 46.1 / 57.0	-	-
Port 4				38.0 / 46.1 / 57.0	38.0 / 46.1 / 57.0	-
Reference output slope (Tilt)	54-1218 MHz		dB	19.0	19.0	19.0
<b>Station Noise Figure</b>						
Noise figure (W/1 dB for input EQ loss)	Typ. @ 54 to 1002 MHz		dB	9.0	9.0	9.0
	Typ. @ 1218 MHz		dB	9.3	9.5	10.5
<b>Station Distortions (Worse Case)</b>				Trunk / Feeder	Feeder	Feeder
Composite Triple Beat (CTB)			-dBc	77 / 67	67	67
Cross Modulation (XMOD)			-dBc	74 / 65	65	64
Composite Second Order (CSO-)	(Vc +0.75 & -1.25 MHz)		-dBc	76 / 67	67	67
Composite Second Order (CSO+)	(Vc +1.25 MHz)		-dBc	76 / 67	67	67
MER			dB	≥40	≥40	≥40
BER			N / A	≤ 1 x 10 <sup>-9</sup>	≤ 1 x 10 <sup>-9</sup>	≤ 1 x 10 <sup>-9</sup>

# Station Parameters 85/105

STATION PARAMETERS:		1218 MHz 85-105 MHz Split		SDA 1218 MHz		
	CONDITIONS	UNITS	SPECIFICATIONS			
Housing passband		MHz	5 to 1218			
Input current capacity	Any port, worst case	Amp	15			
Hum modulation	Time domain @ rated current above	-dBc	65 @ 5-85 MHz 65 @ 105-1218 MHz			
Return loss	Any port, worst case	dB	16.0			
<b>Test Points</b>						
Frequency range		MHz	5 to 85 (Reverse) / 105 to 1218 (Forward)			
Test point type	Directional coupler	N / A				
Test point level	Forward & reverse	-dB	20.0			
Test point accuracy	Forward & reverse	±dB	0.75			
<b>Station Slope</b>			<b>SDAT</b>	<b>SDAM</b>	<b>SDLE</b>	
Operational slope - trunk & feeders	@ 105 / 550 / 1218 MHz	dB	0 / 7.2 / 18.0	0 / 7.2 / 18.0	0 / 7.2 / 18.0	
Slope control type	Cable equalizers	dB	Pad Adjustable EQ's			
Slope control range	Includes cable equivalent	dB	-12.0 to +22.0			
Slope control steps	Equalizer value steps	dB	1.0			
<b>Station Group Delay</b>						
Group delay	Channel A-2	nSec / 3.58 MHz	30			
Group delay	Channel A-1		16			
Group delay	Channel 14		10			
Group delay	Channel 15 & up		3			
<b>AGC</b>			<b>DSIM-A Single Pilot Channel AGC</b>			
Pilot channel type	Up to 1002 MHz	N / A	Analog or QAM			
Compensation range		dB	System compensation input change +4/-8 @ 1218 MHz			
Accuracy		±dB	0.5			
Nominal loss	@ 77 °F (25 °C)	dB	6.25			
<b>Configuration</b>			<b>SDAT</b>	<b>SDAM</b>	<b>SDLE</b>	
<b>Operational Specifications</b>						
Station flatness - Trunk	Normalized w / 0 dB slope	±dB	0.35	-	-	
Station flatness - Feeder	Normalized w / 0 dB slope	±dB	0.50	0.50	0.35	
Gain - Port 2 (W/DSIM)	+1.0 / -0 @ 1218 MHz	dB	38.0	48.0	42.0	
Gain - Port 3 (W/DSIM)		dB	48.0	-	-	
Gain - Port 4 (W/DSIM)		dB	48.0	48.0	-	
Gain - Port 4 (W/DSIM)		dB	48.0	48.0	-	
442 MHz analog channel loading, 74 channels + 660 MHz digital channel loading, 256 QAM at -6 dBc relative to its associated visual carrier						
<b>Station Referenced Output Levels</b>			<b>SDAT</b>	<b>SDAM</b>	<b>SDLE</b>	
Port 2	@ 105 / 550 / 1218 MHz	dBmV	29.0 / 36.2 / 47.0	39.0 / 46.2 / 57.0	39.0 / 46.2 / 57.0	
Port 3			39.0 / 46.2 / 57.0	-	-	
Port 4			39.0 / 46.2 / 57.0	39.0 / 46.2 / 57.0	-	
Reference output slope (Tilt)	105-1218 MHz	dB	18.0	18.0	18.0	
<b>Station Noise Figure</b>						
Noise figure (W/1 dB for input EQ loss)	Typ. @ 105 to 1002 MHz	dB	9.0	9.0	9.0	
	Typ. @ 1218 MHz	dB	9.3	9.5	10.5	
<b>Station Distortions (Worse Case)</b>			<b>Trunk / Feeder</b>	<b>Feeder</b>	<b>Feeder</b>	
Composite Triple Beat (CTB)		-dBc	77 / 67	67	67	
Cross Modulation (XMOD)		-dBc	74 / 65	65	64	
Composite Second Order (CSO-)	(Vc +0.75 & -1.25 MHz)	-dBc	78 / 67	67	67	
Composite Second Order (CSO+)	(Vc +1.25 MHz)	-dBc	77 / 67	67	67	
MER		dB	≥40	≥40	≥40	
BER		N / A	≤ 1 x 10 <sup>-9</sup>	≤ 1 x 10 <sup>-9</sup>	≤ 1 x 10 <sup>-9</sup>	

# Station Parameters 204/258

STATION PARAMETERS:		1218 MHz 204-258 MHz Split		SDA 1218 MHz		
	CONDITIONS	UNITS	SPECIFICATIONS			
Housing passband		MHz	5 to 1218			
Input current capacity	Any port, worst case	Amp	15			
Hum modulation	Time domain @ rated current above	-dBc	65 @ 5-204 MHz 65 @ 258-1218 MHz			
Return loss	Any port, worst case	dB	16.0			
<b>Test Points</b>						
Frequency range		MHz	5 to 204 (Reverse) / 258 to 1218 (Forward)			
Test point type	Directional coupler	N / A				
Test point level	Forward & reverse	-dB	20.0			
Test point accuracy	Forward & reverse	±dB	0.75			
<b>Station Slope</b>			<b>SDAT</b>	<b>SDAM</b>	<b>SDLE</b>	
Operational slope - trunk & feeders	@ 258 / 550 / 1218 MHz	dB	0 / 4.7 / 15.5	0 / 4.7 / 15.5	0 / 4.7 / 15.5	
Slope control type	Cable equalizers	dB	Pad Adjustable EQ's			
Slope control range	Includes cable equivalent	dB	-12.0 to +22			
Slope control steps	Equalizer value steps	dB	1.0			
<b>Station Group Delay</b>						
Group delay	Channel 30	nSec / 3.58 MHz	30			
Group delay	Channel 31		16			
Group delay	Channel 32		10			
Group delay	Channel 33 & up		3			
<b>AGC</b>			<b>DSIM-A Single Pilot Channel AGC</b>			
Pilot channel type	Up to 1002 MHz	N / A	Analog or QAM			
Compensation range		dB	System compensation input change +4/-8 @ 1218 MHz			
Accuracy		±dB	0.5			
Nominal loss	@ 77 °F (25 °C)	dB	6.25			
<b>Configuration</b>			<b>SDAT</b>	<b>SDAM</b>	<b>SDLE</b>	
<b>Operational Specifications</b>						
Station flatness - Trunk	Normalized w / 0 dB slope	±dB	0.35	-	-	
Station flatness - Feeder	Normalized w / 0 dB slope	±dB	0.50	0.50	0.35	
Gain - Port 2 (W/DSIM)	+1.0 / -0 @ 1218 MHz	dB	38.0	48.0	42.0	
Gain - Port 3 (W/DSIM)		dB	48.0	-	-	
Gain - Port 4 (W/DSIM)		dB	48.0	48.0	-	
Gain - Port 4 (W/DSIM)		dB	48.0	48.0	-	
<b>Station Referenced Output Levels</b>			<b>SDAT</b>	<b>SDAM</b>	<b>SDLE</b>	
Port 2	@ 258 / 550 / 1218 MHz	dBmV	31.5 / 36.2 / 47.0	41.5 / 46.2 / 57.0	41.5 / 46.2 / 57.0	
Port 3			41.5 / 46.2 / 57.0	-	-	
Port 4			41.5 / 46.2 / 57.0	41.5 / 46.2 / 57.0	-	
Reference output slope (Tilt)	258-1218 MHz	dB	15.5	15.5	15.5	
<b>Station Noise Figure</b>						
Noise figure (W/1 dB for input EQ loss)	Typ. @ 258 to 1002 MHz	dB	9.0	9.0	9.0	
	Typ. @ 1218 MHz	dB	9.3	9.5	10.5	
<b>Station MER/BER Performance</b>			<b>Trunk / Feeder</b>	<b>Feeder</b>	<b>Feeder</b>	
MER		dB	≥40	≥40	≥40	
BER		N / A	≤ 1 x 10 <sup>-9</sup>	≤ 1 x 10 <sup>-9</sup>	≤ 1 x 10 <sup>-9</sup>	

# Reverse Spectrum

REVERSE SPECTRUM:				SDA 1218 MHz		
REVERSE						
Reverse - General		CONDITIONS	UNITS	SPECIFICATIONS		
Station passband			MHZ	5 to 42, 5 to 85, 5 to 204		
Station flatness - 5 to 42 MHz		Normalized w / 0 dB slope	±dB	0.50		
Station flatness - 5 to 85 MHz		Normalized w / 0 dB slope	±dB	0.50		
Station flatness - 5 to 204 MHz		Normalized w / 0 dB slope	±dB	0.65		
Reverse - Station Gain						
Gain		+1.0 / -0 @ HF	dB	28.0		
Gain control type				JXP Plug-in pads		
Reverse - Station Slope						
Slope control type		Cable equalizers	N / A	Pad Adjustable Eqs		
Slope control range			dB	0 to 15.0		
Slope control steps		Equalizer pad value steps	dB	1.0		
Reverse - Station Group Delay						
Group delay		5 MHz	nSec / 1.5 MHz	45		
Group delay		7 MHz		16		
Group delay		10 MHz		5		
Group delay		35 / 80 / 199 MHz		10		
Group delay		38.5 / 83.5 / 202.5 MHz		25		
Configuration				SDAT	SDAM	SDLE
Reverse - Dynamic Range						
Reference Output Level			dBmV	42.0	42.0	42.0
NPR at 50 dB CNR at 42 MHz		42/53 Split	dB	21.0	21.0	24.0
NPR at 50 dB CNR at 85 MHz		85/105 Split	dB	18.0	18.0	21.0
NPR at 50 dB CNR at 204 MHz		204/258 Split	dB	12.0	12.0	17.0
Reverse - Noise Figure						
Noise figure (W/1 dB for input EQ loss)		5-42 MHz	dB	11.5	11.5	6.0
		5-85 MHz	dB	11.5	11.5	6.0
		5-204 MHz	dB	11.5	11.5	6.5
Power Requirements:						
Max Watts		Includes reverse & DSIM (Worst case)	W	47.2	43.6	26.3
AC Voltage						
Input ranges			VAC	45-90		
Current Draw (with DSIM AGC)						
@ 45 VAC		Maximum	A	1.38	1.21	0.78
@ 50 VAC			A	1.26	1.15	0.69
@ 60 VAC			A	1.10	1.02	0.61
@ 70 VAC			A	0.98	0.91	0.54
@ 80 VAC			A	0.88	0.81	0.50
@ 90 VAC			A	0.80	0.73	0.45
Weight				SDAT	SDAM	SDLE
Weight			lbs. (kg)	16.0 (7.26)	16.0 (7.26)	14.5 (6.58)
Physical						
Dimensions		(H X W X D)	In, (cm)	6.75 X 14.25 X 9.00 (17.1 X 36.2 X 22.9)		
Environmental						
Operating temperature			°F (°C)	-40 to +140 (-40 to +60)		

# Ordering Matrix

## SDA 15 Amp 1218 MHz GaN Product Configuration Worksheet

Customer: \_\_\_\_\_

Created By: \_\_\_\_\_ Order Date: \_\_\_\_\_

### ORDERING MATRIX

March 21, 2022

Position	1	2	3	4	5	6	7	8	9	10	11	12	13	14	15
PART NUMBER							B								

1  STATION TYPE

T = SDAT 3 Output Trunk      W = SDAM 2 or 3 Output Feeder      L = SDLE 1 Output LE

2  BANDWIDTH FREQUENCY

2 = 1218 MHz Upper Frequency

3,4  STATION MAXIMUM FORWARD GAIN

Station Type	TYPE 1	TYPE 2 TRI	TYPE 3
Amplifier Model	SDAT	SDAM	SDLE
Max gain with AGC/ Thermal	38	48	42
Max gain w/AGC bypass	41	51	45

5,6  CONTROL TYPE

D2 = DSIM-A Single Pilot AGC (Analog or Digital pilot) - Pilot channel loaded during setup  
M1 = Manual (AGC Bypass)

7  CURRENT PASSING CAPACITY 15A (Continuous on all ports)

8  STATION SLOPE

	TYPE	54-1218	105-1218	258-1218
V=	SDAT/ SDAM/ SDLE	19.0	18.0	15.5
W=	SDLE ONLY	12.0	11.0	8.5

9  HOUSING OPTIONS

0 = RF Module Only (No housing or power pack)  
E = SDA - Standard with TP

10  DIPLEX FREQUENCY SPLIT

4 = 42/53    8 = 85/105    2 = 204/258

11  STATION GAIN (Reverse)

L = 28 dB min

12  SURGE PROTECTION

A = Version 5 SDA 45-90 VAC power supply and plug-in sidactor

13,14  TEST SPECS (Determined by ACI engineering)

15  SPECIAL/CUSTOMER: LABELS, FUNCTIONS, (Determined by Product Management)

0, 1 = No special instructions      A = GaN Hybrids & Pad adjustable EQ's      N = GaN Forward Hybrids

Generic Order Form: Not all configurations are available



## Accessory Ordering Information:

The SDA ordering matrix provides the part number information to order the configured stations. This page contains the ordering information for the required accessories that will be needed to make the stations functional in the field or the optional accessories that can be ordered separately.

## Required Accessories

Description	Part Numbers (Where XX.X = dB value)
JXP style attenuator pads <ul style="list-style-type: none"> <li>• 1 Required for forward input</li> <li>• 1 Required for reverse output</li> <li>• 1 Required for forward input equalizer</li> <li>• 1 Required for reverse output equalizer</li> </ul>	JXP1.38-XX.X (0 to 20 dB in 0.5 dB steps)

## Optional Accessories

Description	Part Numbers
Digital Station Intelligence Manager - Single Pilot AGC Module (Analog or Digital)	DSIM-A-MDL-1201
Digital Station Intelligence Manager -Controller	DSCT-xxx-yyy xxx = Pilot Channel Number yyy = Channel Type IRC = Analog IRC Spacing DIG = Digital / QAM
DSIM Bluetooth Dongle Apple iOS or android	DSIM-DONGLE-02
Cable assembly DSIM adaptor to connect controller	240330-01
Pad Adjustable Equalizer JXP Platform 0-22 dB	AEQ1.2G
Pad Adjustable Cable Equivalent Equalizers JXP Platform 0-12 dB	ACEQ1.2G
Pad Adjustable Reverse Equalizers 5-42, 85 and 204 MHz JXP Platform 0-12 dB	AREQPE42 AREQPE85 AREQPE204
DC/SP3 Plug-in - SDAM only	SDA1.2-SPLT SDA1.2-DC8 SDA1.2-DC10 SDA1.2-DC12
Test Probe (5.5" Long)	100685-01
Test Probe (1.57" / 4 cm Long)	TP-7504
Test Adapter for Test Probe to Seizure Screw (RF Connector)	100677
Thru-housing Test Cable. Allows reading of internal test points with the housing closed.	240310
EQ Puller Tool	130311
Nut Driver 1/2"	130312
Nut Driver 5/8"	130313

## Optional Accessories (Continued)

Description	Part Numbers
Power Supply (45-90 VAC) Version 5 (RoHS Compliant)	SDA90VSP-V5R
Replacement SDA Housing	SDA-HSG01-00
Metal 5/8" Port Housing Caps	H5/8PLUG
Housing Port Dielectric Insert	030770-01
Seizure Screw / RF Connector 15A 1.2G	100836-01

## Frequency Split Field Conversion Kits

Description	Part Numbers
<b>SDA 1.2G 85/105 Conversion Kits</b>	
Conversion Kit, 85/105 SDAM 18.0 dB Slope	120605-01
Conversion Kit, 85/105 SDAT 18.0 dB Slope	120607-01
Conversion Kit, 85/105 SDLE 18.0 dB Slope	120632-01
Conversion Kit, 85/105 SDLE 11.0 dB Slope	120606-01
<b>SDA 1.2G 204/258 Conversion Kits</b>	
Conversion Kit, 204/258 SDAM 15.5 dB Slope	120608-01
Conversion Kit, 204/258 SDAT 15.5 dB Slope	120610-01
Conversion Kit, 204/258 SDLE 15.5 dB Slope	120633-01
Conversion Kit, 204/258 SDLE 8.5 dB Slope	120609-01



ACI Communications, Inc.  
23307 66th Avenue South  
Kent, WA 98032

Rev N 12-01-2022 Printed in U.S.A.  
ACI Communications, Inc. reserves the right to discontinue the manufacture or change specifications without prior notice on any parts illustrated in this data sheet. ACI and DSIM are registered trademarks and ASEM and ACION are trademarks of ACI. Other trademarks are the property of their respective owners, and ACI is in no way affiliated with these companies.